

# Free Floating Guided Lever Drain Traps

For Loads to 22 300 kg/h...Pressures to 21 bar

Armstrong's cast iron, free-floating guided lever drain traps use the same bodies, caps, lever mechanisms, valves and seats of Armstrong inverted bucket steam traps that have been proven in years of service. Elliptical floats and high leverage make it possible to open large orifices to provide adequate capacity for drain trap size and weight.

The hemispherical valve, seat and leverage of the 1-LD, 2-LD, 3-LD and 6-LD cast iron traps are identical in design, materials and workmanship to those for saturated steam service up to 21 bar with the exception of the addition of a guidepost to assure a positive, leaktight valve closing under all conditions.

**Table LD-393-1. Guided Lever LD List of Materials**

Model No.	Valve & Seat	Leverage System	Float	Body & Cap	Gasket
1-LD 2-LD 3-LD 6-LD	Stainless Steel			Cast Iron ASTM A48 Class 30	Compressed Asbestos-free

For information on special materials, consult the Armstrong Application Engineering Department.

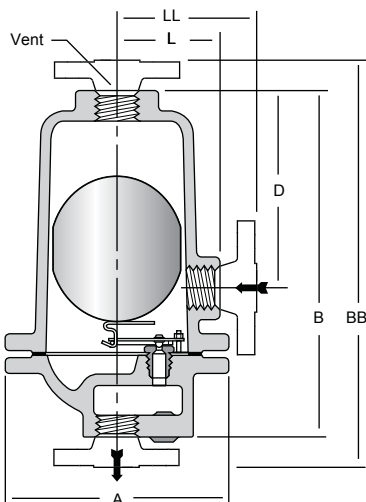

**Figure LD-393-1.**

Models 2-LD, 3-LD and 6-LD cast iron guided lever drain traps.  
Model 1-LD has standard top inlet and optional side connection.



**Table LD-393-2. Physical Data Armstrong Guided Lever Liquid Drain Traps (dimensions in mm)**

Model No.	Cast Iron			
	1-LD	2-LD	3-LD	6-LD
Pipe Connections	15*	15 – 20	15 – 20 – 25	40 – 50
"A"	95	133	162	259
"B"	140	203	273	432
"BB" (PN40**)	N/A	320 – 330	400 – 392	562 – 568
"D"	73	111	155	213
"K" (Q Outlet to Q Inlet)	21	—	—	—
"L"	48	62	73	123
"LL" (PN40**)	N/A	179 – 189	142 – 134	180 – 186
Weight in kg (screwed)	1,8	6	10	36
Weight in kg (flanged PN40**)	N/A	8,7 – 9,6	13,6 – 14,2	42,6 – 45,0
Maximum Allowable Pressure (Vessel Design)††	21 bar @ 93°C	17 bar @ 232°C		17 bar @ 232°C

**Note:** Vessel design pressure may exceed float collapse pressure in some cases.

Pipe size of vent connection is same as that of inlet and outlet connections.

\* 1/4" outlet.

\*\* Other flange sizes, ratings and face-to-face dimensions are available on request.

† For pressures not exceeding 17 bar, a maximum temperature of 232°C is allowed.

†† May be derated depending on flange rating and type.

Shade indicates products that are CE Marked according to the PED (2014/68/UE). All the other models comply with the Article 4.3 of the same directive.

**All dimensions and weights are approximate. Use certified print for exact dimensions. Design and materials are subject to change without notice.**



# Free Floating Guided Lever Drain Traps

For Loads to 4 300 kg/h...Pressures to 39 bar



CHRYSSAFIDIS

Armstrong's stainless steel, free-floating guided lever drain traps use the same bodies, caps, lever mechanisms, valves and seats of Armstrong inverted bucket steam traps that have been proven in years of service. Elliptical floats and high leverage make it possible to open large orifices to provide adequate capacity for drain trap size and weight.

The hemispherical valve, seat and leverage of the 11-LD, 22-LD and 13-LD stainless steel traps are identical in design, materials and workmanship to those for saturated steam service up to 39 bar with the exception of the addition of a guidepost to assure a positive, leaktight valve closing under all conditions.

Table LD-394-1. 10-LD List of Materials					
Model No.	Valve & Seat	Leverage System	Float	Body & Cap	Gasket
11-LD 22-LD 13-LD	Stainless Steel			Sealed Stainless Steel, 304L	—

For information on special materials, consult the Armstrong Application Engineering Department.

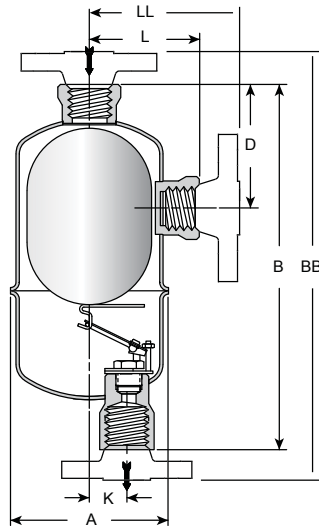

Figure LD-394-1.

Models 11-LD, 22-LD and 13-LD stainless steel guided lever liquid drain trap with sealed, tamperproof construction.



Table LD-394-2. 10-LD Physical Data (dimensions in mm)			
Model No.	Stainless Steel		
	11-LD**	22-LD	13-LD
Pipe Connections	20*	20	25
"A"	70	100	114
"B"	183	221	289
"BB" (PN40***)	228 – 232	271	375
"D"	—	83	156
"K"	14	22	30
"L"	—	67	83
"LL" (PN40***)	—	117	126
Weight in kg (screwed & SW)	0,8	2,3	3,4
Weight in kg (flanged PN40***)	2,9 – 4,0	5,2	7,3
Maximum Allowable Pressure (Vessel Design)†	34 bar @ 38°C 30 bar @ 260°C	41 bar @ 38°C 33 bar @ 260°C	39 bar @ 38°C 34 bar @ 260°C

Note: Vessel design pressure may exceed float collapse pressure in some cases.

Pipe size of vent connection is same as that of inlet and outlet connections.

\* 1/2" outlet.

\*\* No side connection

\*\*\* Standard flanges are in carbon steel, stainless steel flanges are optional. Other flange sizes, ratings and face-to-face dimensions are available on request. Shade indicates products that are CE Marked according to the PED (2014/68/UE). All the other models comply with the Article 4.3 of the same directive.

† May be derated depending on flange rating and type.

**All dimensions and weights are approximate. Use certified print for exact dimensions. Design and materials are subject to change without notice.**

Armstrong International SA • Parc Industriel des Hauts-Sarts (2<sup>e</sup> Avenue) • 4040 Herstal • Belgium

Tel.: +32 (0)4 240 90 90 • Fax: +32 (0)4 240 40 33

www.armstronginternational.eu • info@armstronginternational.eu

LD-394

